

# TPE Expansion Seal - 40mm x 35.9mm

Product Code: RCES2695

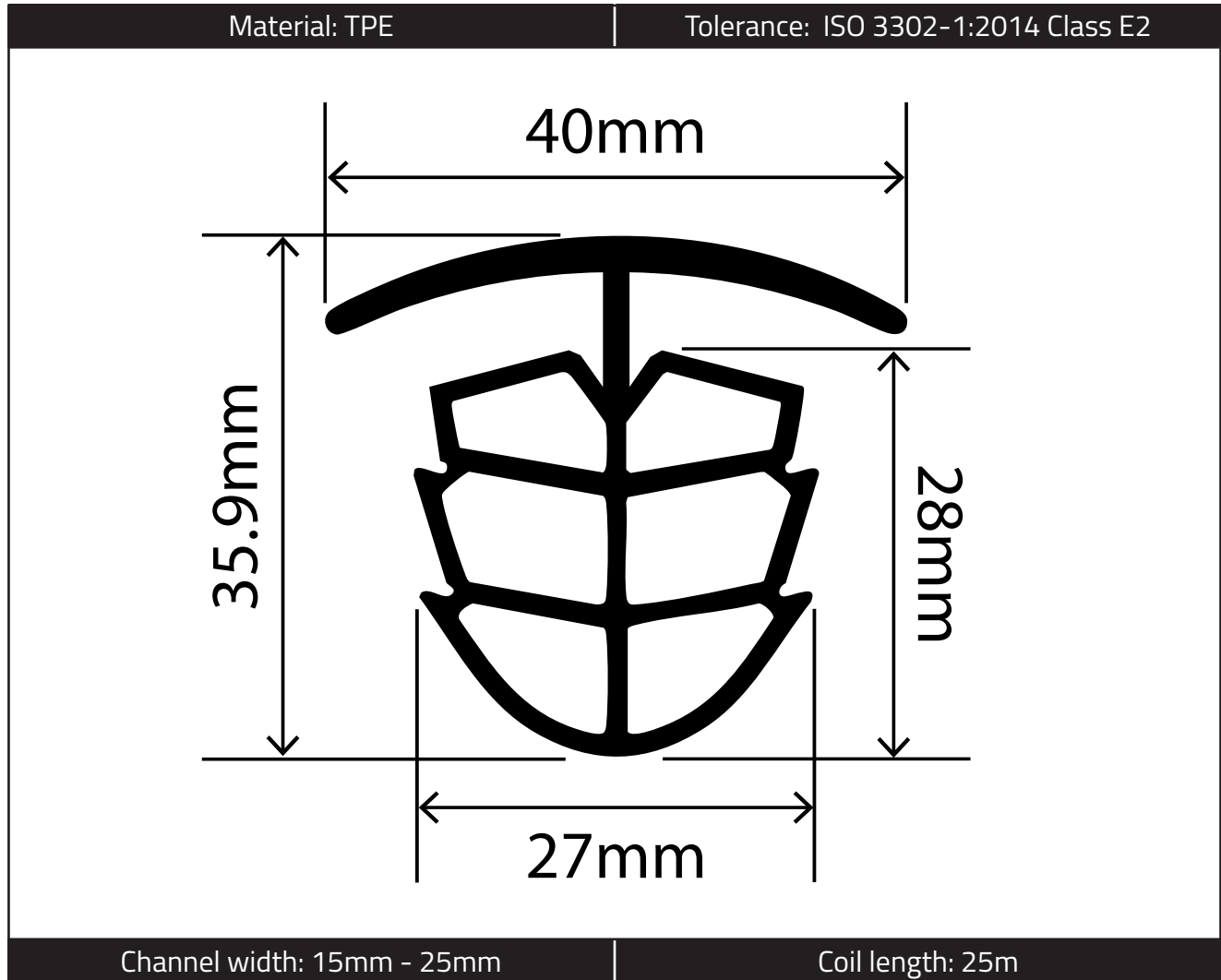

The information contained on this product information sheet is to be used as guidance. The advice is given in good faith and does not constitute any guarantee or recommendation for suitability. The Rubber Company cannot be held liable for any damage caused by incorrect installation. We hereby reserve the right to change the technical information herewith without notification or prior agreement.

E [sales@therubbercompany.com](mailto:sales@therubbercompany.com)

W [www.therubbercompany.com](http://www.therubbercompany.com)

T +44 (0) 1794 513 184

The Rubber Company Limited - Registered in England and Wales  
Company Number - 08350831 | VAT Number - GB 156 8355 80



## Technical Data

Property	Test Method	Value
Compound	-	TPV (PP-EPMD)
Colour	-	Black
Hardness (Shore A)	ISO 868	70°
Density (Specific Gravity)	ISO 2781	1.18
Tensile Strength	ISO 37	7.4 MPa
Remanent Deformation After Compression (24 h @ 70° C)	ISO 815-B	48 %
Remanent Deformation After Compression (24 h @ 100° C)	ISO 815-B	65 %
Remanent Deformation After Compression (72 h @ 23° C)	ISO 815-B	23 %
Working Temperature Range	-	-50° C to +90° C

## Approvals



The information contained on this product information sheet is to be used as guidance. The advice is given in good faith and does not constitute any guarantee or recommendation for suitability. The Rubber Company cannot be held liable for any damage caused by incorrect installation. We hereby reserve the right to change the technical information herewith without notification or prior agreement.