

## RubbaClean-TS Entrance Matting

Product Code: R-CLEAN-CRS-TS

### Key Features

- Durable aluminium entrance matting with textile and scrub insert
- Anti-slip to DIN 51130:2014-02 R11/R13
- Flame-retardant to Cfl-s1
- Excellent dirt, mud and snow scraping action
- Good moisture absorbancy
- Suitable for high foot traffic
- Easy to clean and maintain

### Attributes



Anti-Slip



Flame Retardant



Durable

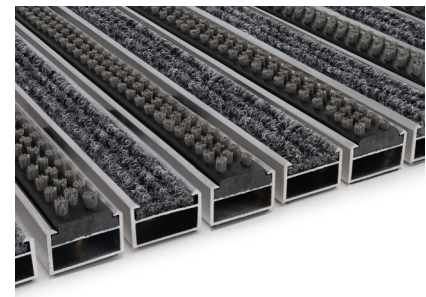

### Technical Data

Property	Test Method	Value
Profile Material	-	Aluminium EN AW 6063 T6
Application	-	For Indoor Use
Working Temperature Range	-	+5° C and Above
Hygiene Certification	-	HK/B/0628/1/2014
Slip Resistance	DIN 51130:2014	R11 / R13
Fire Classification	PN-EN 13501-1 + A1:2010	Cfl-s1
Static Load	-	3500 kg / 100 cm <sup>2</sup> - Standard Version 10000 kg / 100 cm <sup>2</sup> - Strong Version
<b>Textile Insert</b>		
Manufacturing Process	-	Felting
Fibre Composition	ISO 2424	100% Polypropylene (pp)
Fibre Weight	-	1180 g/m <sup>2</sup>
Fibre Height	ISO 1765	4mm

The information contained on this product information sheet is to be used as guidance. The advice is given in good faith and does not constitute any guarantee or recommendation for suitability. The Rubber Company cannot be held liable for any damage caused by incorrect installation. We hereby reserve the right to change the technical information herewith without notification or prior agreement.

Property	Test Method	Value
Total Mass	ISO 8543	3630 g/m <sup>2</sup> ± 15 %
Total Thickness	ISO 1765	9.5mm +15 % / - 10 %
Material Permanently Anti-Static	ISO 6356	-
<b>Scrub Insert</b>		
Material	-	Polypropylene
PA6.6 Fibre Thickness	-	0.4mm
Stainless Steel Wire Thickness	-	0.7mm
According to the manufacturers declaration, the scrub insert meets the requirements of EU Directive 2002/95/EC, which entered into force on 01/07/2006, and is manufactured in accordance with Directive RoHS 2002/95/EC.		

## Matting Profile

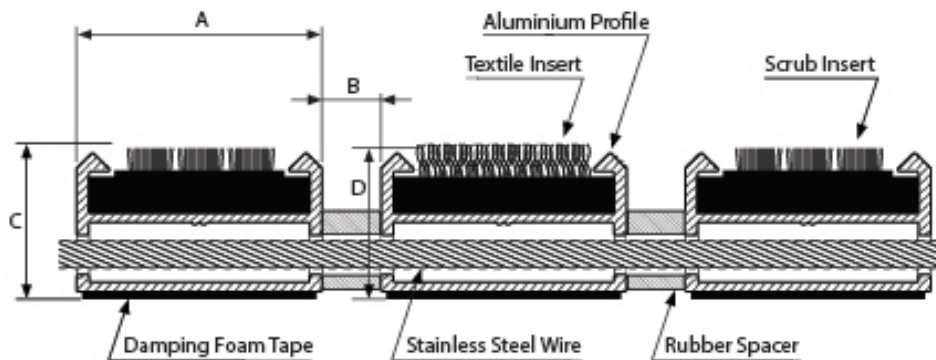

## Measurements

Matting Type	Height (mm)	A (mm)	B (mm)	Scrub C (mm)	Textile D (mm)
RubbaClean-TS Entrance Matting - Standard	12	30	3-5	18	15
RubbaClean-TS Entrance Matting - Standard	17	30	3-5	22	18
RubbaClean-TS Entrance Matting - Standard	22	30	3-5	25	22
RubbaClean-TS Entrance Matting - Standard	27	30	3-5	32	28
RubbaClean-TS Entrance Matting - Strong	22	32	3-5	25	22
RubbaClean-TS Entrance Matting - Premium	22	51	3-5	25	22

The information contained on this product information sheet is to be used as guidance. The advice is given in good faith and does not constitute any guarantee or recommendation for suitability. The Rubber Company cannot be held liable for any damage caused by incorrect installation. We hereby reserve the right to change the technical information herewith without notification or prior agreement.

## Approvals



The information contained on this product information sheet is to be used as guidance. The advice is given in good faith and does not constitute any guarantee or recommendation for suitability. The Rubber Company cannot be held liable for any damage caused by incorrect installation. We hereby reserve the right to change the technical information herewith without notification or prior agreement.